

USERS MANUAL

4-IN-1 BRAD NAILER/STAPLER & FLOORING NAILER

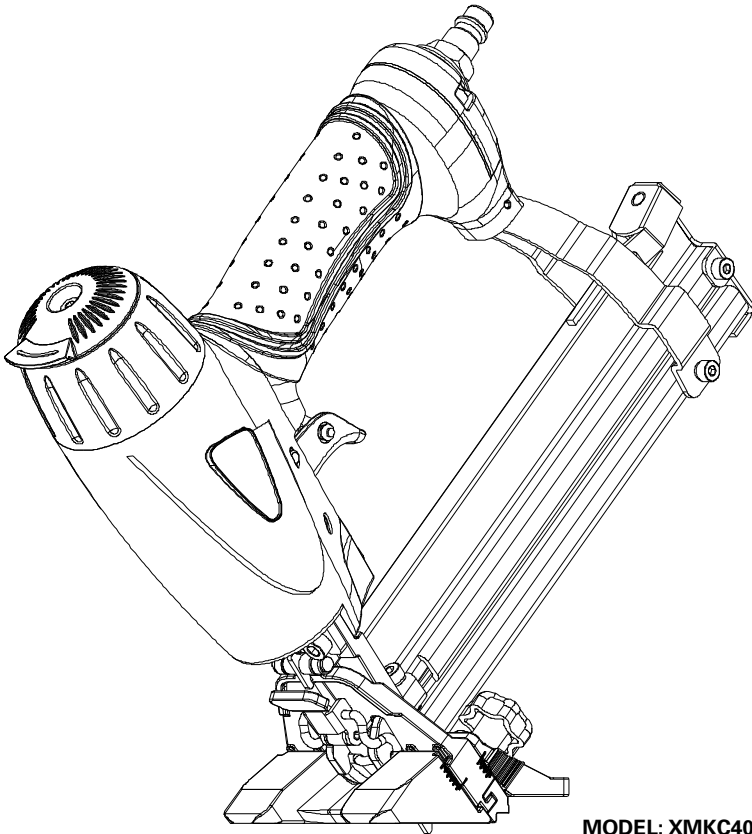

MODEL: XMKC40/9040III



WARNING

Failure to follow warning could result in DEATH OR SERIOUS INJURY.

M0519 03/13 V1

CONTENTS:

IMPORTANT INFORMATION	P1
EXPLANATION OF THE NAILING ACTION	P1
GENERAL SAFETY RULES	P1
WORK AREA	P1
PERSONAL SAFETY	P1
TOOL USE AND CARE	P1
SERVICE	P2
AIR SOURCE	P2
DESCRIPTION AND SPECIFICATION	P3
SPECIFICATION	P3
FEATURES	P4
ASSEMBLY/INSTALLATION	P4
OPERATION	P4
LUBRICATION	P4
ADJUSTING AIR PRESSURE	P4
CONNECTING AIR SUPPLY	P4
TOOL TESTING	P5
NAIL LOADING	P5
METHODS OF OPERATION	P6
COLD WEATHER OPERATION	P6
ADJUSTING THE NAILING DEPTH	P6
ADJUSTABLE THE EXHAUST	P7
NAIL INDICATOR	P7
CHANGE THE NOSE COVER	P7
MAINTENANCE	P8
JAM CLEARING	P8
CLEANING	P8
STORAGE	P8
HOOKUP INSTRUCTIONS FOR TOOL TO AIR SUPPLY	P8
RECOMMENDED HOOKUP	P9
TROUBLE SOLVING	P9

IMPORTANT INFORMATION

WARNING

TO AVOID SERIOUS PERSONAL INJURY, ALL USERS AND EMPLOYERS/OWNERS MUST READ AND UNDERSTAND ALL INSTRUCTIONS IN THIS MANUAL BEFORE OPERATING OR MAINTAINING THIS TOOL.

keep this manual for the safety warnings and precautions, operating, inspection, maintenance. Keep this manual and the receipt in a safe and dry place for future reference.

EXPLANATION OF THE NAILING ACTION

◆ SINGLE ACTUATION MECHANISM:

First, press the safety against the wood; next, pull the trigger to drive the fastener. After fastening once, fastening will not be possible again until the trigger is released and pressed again.

◆ CONTACT ACTUATION MECHANISM:

First, press the safety against the wood; next, pull the trigger to drive the fastener. First. Pull the trigger; next, press the safety against the wood to drive the fastener. If the trigger is held back, a fastener will be driven each time when the safety is pressed against the wood.

◆ FULL SEQUENTIAL ACTUATION MECHANISM:

First, press the safety against the wood; next, pull the trigger to drive the fastener. Follow the same sequence to continue driving fasteners.

GENERAL SAFETY RULES

WORK AREA

- ◆ **KEEP THE WORK AREA CLEAN AND WELL LIGHTED.**
Cluttered benches and dark areas increase the risks of accidents.
- ◆ **DO NOT OPERATE THE TOOL IN EXPLOSIVE ATMOSPHERES,** such as in the presence of flammable liquids, gases, or dust. The tool creates a spark which may ignite flammable liquids, gases or dust.
- ◆ **KEEP VISITORS AWAY.** Do not let visitors handle the tool. All visitors should be kept safety away from work area.
- ◆ **NEVER ENGAGE IN HORSEPLAY WITH THE TOOL.**
Respect the tool as a working implement.

PERSONAL SAFETY

- ◆ **OPERATORS AND OTHERS IN WORK AREA MUST WEAR SAFETY GLASSES WITH SIDE SHIELDS.** When operating the tool, always wear safety glasses with side shields, and make sure others in work area wear safety glasses. Safety glasses must conform to the requirements of American National Standards Institute, ANSI Z87.1 and provide protection against flying particles both from the front and side.

The employer must enforce the use of safety glasses by the tool operator and others in work area.

- ◆ **ALWAYS WEAR EAR AND HEAD PROTECTION.** Always wear ear protection to protect your ears from loud noise, Always wear head protection to protect your head from flying objects.
 - ◆ **USE SAFETY EQUIPMENT.** A dust mask, non-skid safety shoes and a hard hat must be used for the applicable conditions. Wear a full face shield if you are producing metal filings or wood chips.
 - ◆ **DRESS PROPERLY.** Do not wear loose clothing or jewelry. Contain long hair. Keep your hair, clothing, and gloves away from moving parts. Loose clothes, jewelry, or long hair can be caught in moving parts and increases the risk of injury.
 - ◆ **STAY ALERT, WATCH WHAT YOU ARE DOING AND USE COMMON SENSE WHEN OPERATING A POWER TOOL.** Do not use tool while tired or under the influence of drugs, alcohol, or medication. A moment of inattention while operating the tool may cause serious injury.
 - ◆ **AVOID UNINTENTIONAL FIRING.** Keep fingers away from trigger when not driving fasteners, especially when connecting the tool to the air supply.
 - ◆ **DO NOT OVERREACH.** keep proper footing and balance at all times. Proper footing and balance enable better control of the tool in unexpected situations.
 - ◆ **MAKE SURE AIR HOSE IS FREE OF SNAGS AND OBSTRUCTIONS. DO NOT ATTACH AN AIR HOSE OR TOOL TO YOUR BODY.** Entangled or snarled hoses can cause a loss of balance or footing in addition to unintentional tool operation. Attach the hose to the structure to reduce the risk of loss of balance of the hose shifts.
- ### **TOOL USE AND CARE**
- ◆ **NEVER POINT TOOL AT YOURSELF OR OTHERS IN WORK AREA.** Always assume the tool contains fasteners. Never point the tool at yourself or others, whether it contains fasteners or not. If fasteners are mistakenly driven, it can lead to severe injuries. Never engage in horseplay with the tool. Respect the tool as a working implement.
 - ◆ **KEEP FINGERS AWAY FROM TRIGGER WHEN NOT DRIVING FASTENERS TO AVOID ACCIDENTAL FIRING.** Never carry the tool with finger on trigger since you could drive a fastener unintentionally and injure yourself or someone else. Always carry the tool by the handle only.
 - ◆ **NEVER MODIFY OR ALTER A TOOL.** Doing so may cause malfunction and personal injuries.
 - ◆ **KNOW THIS TOOL.** Read manual carefully, learn its applications and limitations, as well as the specific potential hazards related to this tool.
 - ◆ **USE ONLY FASTENERS THAT ARE RECOMMENDED FOR YOUR MODELS.** Do not use the wrong fasteners or load the fasteners incorrectly.
 - ◆ **CHECK FOR MISALIGNMENT OR BINDING OF MOVING PARTS, BREAKAGE OF PARTS, AND ANY OTHERS**

CONDITION THAT MAY AFFECT THE TOOL'S OPERATION. If damaged, have the tool serviced before using. Many accidents are caused by poorly maintained tools.

- ◆ **CHECK SAFETY BEFORE USE.** Make sure the safety operates properly. Never use the tool unless the safety is operating properly, otherwise the tool could drive a fastener unexpectedly. Do not tamper with or remove the safety, otherwise the safety becomes inoperable.
- ◆ **DO NOT USE TOOL IF TRIGGER DOES NOT ACTUATE PROPERLY.** Any tool that cannot be controlled with the trigger is dangerous and must be repaired.
- ◆ **NEVER USE TOOL WHICH IS DEFECTIVE OR OPERATING ABNORMALLY.** If the tool appears to be operating unusually, making strange noises, or otherwise appears defective, stop using it immediately and arrange for repairs by an authorized service center.
- ◆ **MAINTAIN TOOLS WITH CARE.** Keep the tool clean and lubricated for better and safer performance.
- ◆ **NEVER CARRY THE TOOL BY AIR HOSE.**
- ◆ **STORE TOOLS OUT OF THE REACH OF CHILDREN AND OTHER UNTRAINED PEOPLE.** Tools are dangerous in the hands of untrained users.
- ◆ **PLACE TOOL PROPERLY ON WORKPIECE.** Do not drive fasteners on top of other fasteners or with the tool at too steep of an angle; the fasteners can ricochet and hurt someone.
- ◆ **DO NOT USE THE TOOL AS A HAMMER.**
- ◆ **KEEP ALL SCREWS AND COVERS TIGHTLY IN PLACE.**
- ◆ **KEEP FACE, HANDS AND FEET AWAY FROM FIRING HEAD AT ALL TIMES.** Never place your face, hands or feet near the firing head.
- ◆ **DO NOT DISCONNECT AIR HOSE FROM TOOL WITH FINGER ON TRIGGER.** The tool can fire when re-connected to an air supply.
- ◆ **DO NOT LOAD FASTENERS WITH TRIGGER PULLED OR SAFETY DEPRESSED.**
- ◆ **NEVER PLACE A HAND OR ANY PART OF BODY IN FASTENER DISCHARGE AREA OF TOOL.**
- ◆ **DO NOT DRIVE FASTENERS INTO THIN BOARDS OR NEAR CORNERS AND EDGES OF WORKPIECE.** The fasteners can be driven a way from the workpiece hit someone.
- ◆ **DISCONNECT AIR HOSE FROM TOOL WHEN:**
 - 1). Doing maintenance and inspection;
 - 2). Turning the adjuster and top cover;
 - 3). Clearing a jam;
 - 4). It is not in use;
 - 5). Leaving work area;
 - 6). Moving it to another location;
 - 7). Handing it to another person.

Never attempt to clear a jam or repair the tool unless you have disconnected air hose from the tool and removed all remaining fasteners from the tool. The tool should never be left unattended since people who are not familiar with the tool might handle it and injure themselves.

TOOL SERVICE

- ◆ **USE ONLY ACCESSORIES THAT ARE IDENTIFIED BY THE MANUFACTURER FOR THE SPECIFIC TOOL MODEL.**
- ◆ **USE OF UNAUTHORIZED PARTS OR FAILURE TO FOLLOW MAINTENANCE INSTRUCTIONS MAY CREATE A RISK OF INJURY.**
- ◆ **USE ONLY THE LUBRICANTS SUPPLIED WITH THE TOOL OR SPECIFIED BY THE MANUFACTURE.**
- ◆ **TOOL SERVICE MUST BE PERFORMED ONLY BY QUALIFIED REPAIR PERSONNEL.**

AIR SOURCE

- ◆ **NEVER USE OXYGEN OR OTHER BOTTLED GASES AS A POWER SOURCE.** Explosion may occur. Combustible gases and other bottled gases are dangerous and may cause the tool to explode.
- ◆ **DO NOT EXCEED MAXIMUM RECOMMENDED AIR PRESSURE MARKED ON THE TOOL.** Use only clean, dry, regulated, compressed air within the rated pressure range marked on the tool. Never connect the tool to pressure as which potentially exceeds 200PSI the tool can burst.
- ◆ **DO NOT ABUSE THE AIR HOSE.** Protect all hoses from kinks, restrictions, solvents or sharp objects. Keep air hose away from heat, oil, sharp edges or moving parts. Replace damaged hoses immediately. Damaged hoses can burst or whip around.
- ◆ **CHECK ALL FITTINGS, HOSES, PIPES, CONNECTIONS AND COMPRESSOR BEFORE EACH USE OF THIS TOOL.** Repair or replace damaged or leaking hoses and connections immediately. Damage to a hose or connection can cause a pressure hose to break and whip around the work area, and can lead to injury.

FUNCTIONAL DESCRIPTION AND SPECIFICATIONS

⚠ WARNING

Disconnect the tool from the air source before making any adjustments, changing accessories or storing the tool. Such precautionary safety measures reduce the risk of unintentional tool operation.

FIG. 1

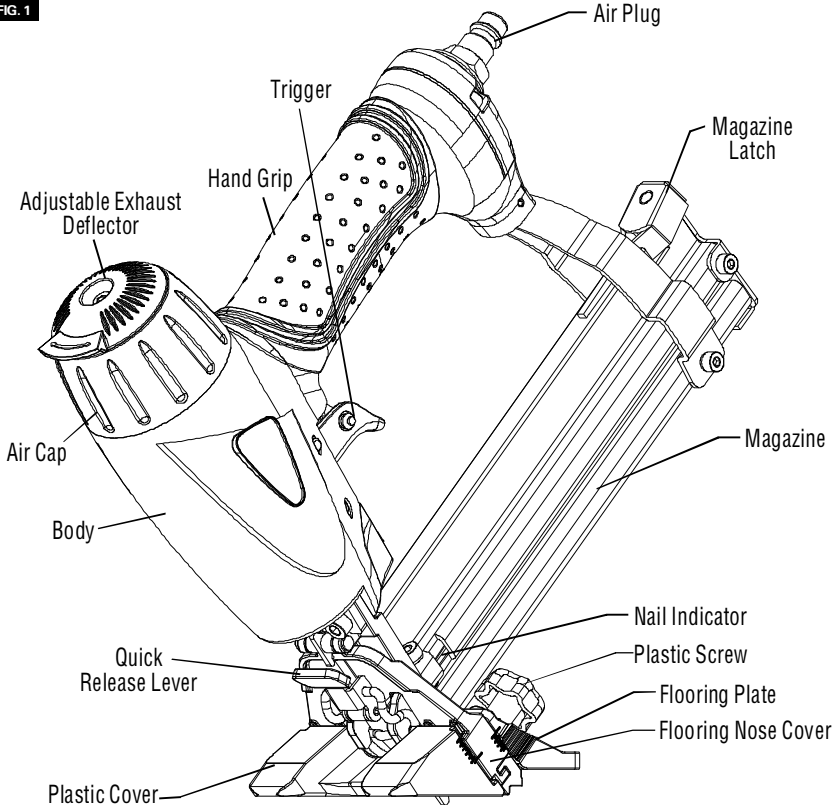

SPECIFICATIONS

Product Size:

Length – 12.99"(330mm)

Height – 10.51"(267mm)

Width – 2.99"(76mm)

Weight: 3.52lbs(1.6kg)

Normal Operating Pressure: 70–110PSI(0.5–0.75MPa)

Magazine Capacity: 100 Nails

Firing Mode: Sequential Fire

Fastener Size Range:

18 Gauge Brads: 5/8"–1-5/8"(15–40mm)

18 Gauge Staples: 1/2"–1-5/8"(13–40mm)

Fastener Type

21mm(0.079")

15mm 5/8"

20mm 3/4"

25mm 1"

30mm 1-3/16"

32mm 1-1/4"

40mm 1-5/8"

1.26 x 1.05mm

(0.050" / 0.041")

18Ga.

5.7mm(1/4")

13mm 1/2"

16mm 5/8"

19mm 3/4"

25mm 1"

32mm 1-1/4"

40mm 1-5/8"

1.26 x 1.05mm

(0.050" / 0.041")

18Ga.

FEATURES

- ◆ 360° exhaust direction.
- ◆ Adjustable depth of drive.
- ◆ New designed 4-IN-1 tool, ordinary 2-IN-1 tool and flooring 2-IN-1 tool.
- ◆ Nose interchangeable.

ASSEMBLY/INSTALLATION

Follow the instructions below to prepare your tool for operation.

1. All tool operators and their immediate supervisors must become familiar with the operator safety instructions before operating the tool.
2. Included with each tool are one copy of these Operating/Safety Instructions. Keep this publications for future reference.
3. Install a filter, regulator, lubricator unit and moisture trap on your air delivery system per the manufacturer's instructions for these devices. Additionally, install a pressure gauge as close as practical to the tool, preferably within 10 feet.
4. Select hoses with a minimum inner diameter of 1/4 inches and a maximum length of 100 feet.

⚠ WARNING

To reduce the risk of injury from a hose bursting, select hoses that are rated at least 200PSI.

5. Select fittings that are appropriate size for the selected hoses. The tool and air hose must have a hose coupling so that all pressure is removed from the tool when the coupling joint is disconnected.

⚠ WARNING

Never use non relieving couplers and/or female quick disconnect couplings on the tool. Non relieving couplings and female couplings will trap high pressure air in the tool when the air line is disconnected. This will leave the tool charged with enough air after it has been disconnected to drive a nail. Only MALE pneumatic type air connectors should be fitted to the tool, so that high pressure air in the tool is vented to atmosphere as soon as the air line is disconnected.

6. Set the regulator at the air delivery system to a PSI that falls within the tool's operating range of 70-110PSI. The correct pressure is the lowest pressure that will do the job.

OPERATION

LUBRICATION

⚠ WARNING

USE ONLY THE AIR TOOL LUBRICANTS SUPPLIED WITH THE TOOL. Do not use other lubricants as they may damage the tool.

4

If the tool is not used with an in-line lubrication system on the air supply it is necessary to periodically lubricate the tool with air tool lubrication.

Under low use, lubricate once a day. Under heavy use, lubricate twice a day. To lubricate, insert 2-3 drops of lubricant into the air supply fitting attached to the tool handle (FIG 2). Using too much oil will cause it to collect in the tool and be noticeable in the exhaust.

FIG. 2

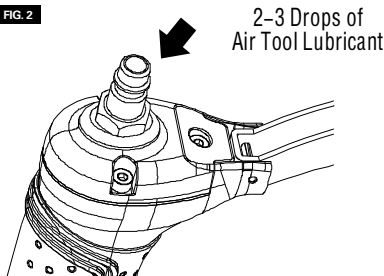

Do not use detergent oil, WD-40, transmission fluid, motor oil, or other lubricants not specifically designated as air tool lubricants. These lubricants will cause accelerated wear to the seals, o-rings, and bumpers in the tool, resulting in poor tool performance and frequent maintenance.

ADJUSTING AIR PRESSURE

Adjust the air pressure at recommended operating pressure 70-110PSI according to the length of nails and the hardness of workpiece.

The correct air pressure is the lowest pressure which will do the job. Using the tool at a higher than required air pressure unnecessarily over stresses the tool. Don't exceed 115PSI.

FIG. 3

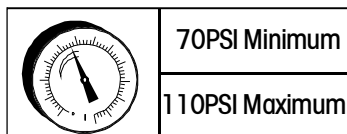

CONNECTING AIR SUPPLY

⚠ WARNING

Never use oxygen or other bottled gases as a power source. Explosion may occur. Combustible gases and other bottled gases are dangerous and may cause the tool to explode.

⚠ WARNING

Never connect the tool to an air source that is capable of producing air pressure exceeding 200PSI. Excessive pressure can cause abnormal operation or cause the tool to burst, resulting in personal injury.

⚠ WARNING

Do not exceed maximum recommended air pressure marked on the tool. Verify prior to using the tool that the air source has been adjusted within the rated air-pressure rang. Be sure the air pressure gauge is operating properly and check it at least twice a day. Tools operated in excess of their maximum pressure rating may operate abnormally or burst resulting in personal injury.

To connect the tool to the compressor only use pneumatic air hoses that meet the following criteria:

1. Minimum hose pressure rating, 200PSI.
2. Minimum hose inner diameter, 1/4 in.
3. Maximum hose length, 100 ft.

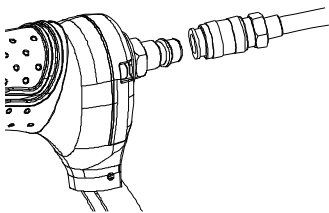

FIG. 4

Connect the air supply:

- Snap the air hose onto the quick connector.
- Check for air leakage. If leakage is noted, stop using the tool immediately and performed by qualified repair personnel.
- Be sure the air pressure gauge is operating properly and check it at least twice a day.

TOOL TESTING

⚠ DANGER

OPERATORS AND OTHERS IN WORK AREA MUST WEAR SAFETY GLASSES WITH SIDE SHIELDS WHICH CONFORMS TO ANSI Z87.1 SPECIFICATIONS.

⚠ WARNING

NEVER USE TOOL UNLESS SAFETY IS OPERATING PROPERLY.

Before actually beginning the nailing work, test the tool by using the check list below. Conduct the test in the following order.

If abnormal operation occurs, stop using the tool and performed by qualified repair personnel immediately.

1. Disconnect air hose from tool. Remove all nails from tool.
 - **ALL SCREWS MUST BE TIGHTENED.** If any screws are loose, tighten them.
 - **THE SAFETY AND TRIGGER MUST MOVE SMOOTHLY.**
2. Adjust the air pressure to 70PSI, connect the air hose. Do not load any nails in the tool.
 - **THE TOOL MUST NOT LEAK AIR.**
3. Remove the finger from the trigger and press the safety

against the wood.

- **THE TOOL MUST NOT OPERATE.**

4. Separate the safety from the wood. Next, point the tool downward, pull the trigger and then wait in that position for 5 seconds or longer.

- **THE TOOL MUST NOT OPERATE.**

5. 1). Without touching the trigger, depress the safety against the workpiece. Pull the trigger.

- **THE TOOL MUST OPERATE**

- 2). Hold the trigger back while separating the safety from the wood.

The tool will remain in operated status(the driver blade will remain at the bottom).

- 3). Remove the finger from the trigger.

Tool operation will end (the driver blade will return to the top).

6. If no abnormal operation is observed, you may load nails in the tool. Drive nails into the workpiece that is the same type to be used in the actual application.

- **THE TOOL MUST OPERATE PROPERLY.**

NAIL LOADING

⚠ WARNING

When loading the tool's magazine, check that the nail tips contact the wear rail and slide smoothly against the surface of the magazine. If the nails are not loaded properly, the tool will misfire and nails can be deflected, causing the tool to react in an unexpected manner, and damage the tool.

1. Connect air supply.
2. Press magazine latch and pull magazine to open position (FIG 5).
3. See tool specification to determine appropriate nail sizes. Insert appropriate nail strips, with the nail tips contacting the wear rail (FIG 6).
4. Push the nail strip against the nose.
5. Push magazine fully closed. Magazine latch will maintain fully closed position.

FIG. 5

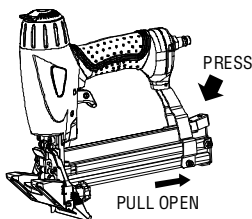
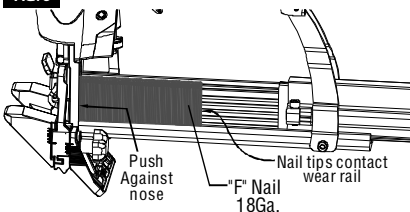
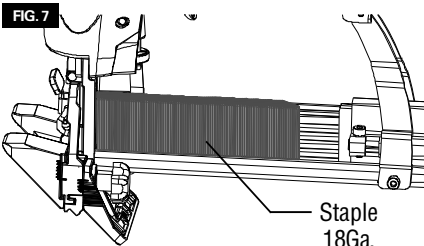

FIG. 6





⚠ WARNING

KEEP THE TOOL POINTED AWAY FROM YOURSELF AND OTHERS WHEN LOADING FASTENERS. FAILURE TO DO SO COULD RESULT IN POSSIBLE SERIOUS PERSONAL INJURY.

NEVER LOAD FASTENERS WITH THE WORKPIECE CONTACT OR TRIGGER ACTIVATED. DOING SO COULD RESULT IN POSSIBLE SERIOUS PERSONAL INJURY.

REMOVING THE NAILS:

1. Disconnect air supply.
2. Press magazine latch and pull magazine to open position (FIG 5).
3. Grasp the head of the nail strip and remove from magazine.

METHODS OF OPERATION

This tool is equipped with the safety and does not operate unless the safety is depressed. The methods of operation to drive nails with this tool is sequential actuation mechanism.

- 1). Position the nail outlet on the workpiece with finger off the trigger.
- 2). Depress the safety firmly until it is completely depressed.
- 3). Pull the trigger to drive a nail.
- 4). Remove finger from the trigger.

To continue nailing a separate location, move the tool along the wood, repeating steps (2–4) as required.

NOTE:

- Always handle nails and package carefully. If nails are dropped, collating bent may be broken, which will cause mis-feeding and jamming.
- After nailing:
 - 1). Disconnect air hose from the tool.
 - 2). Remove all nails from the tool.
 - 3). Supply 5–10 drops of pneumatic tool lubricant into the air plug on the tool.
 - 4). Open the petcock on the air compressor tank to drain any moisture.

COLD WEATHER OPERATION

⚠ WARNING

DO NOT USE A FROZEN TOOL. Allow tool to thaw before using. Moisture frozen in the tool may impede internal components resulting in the risk of injury and/or tool damage.

When using the tool in cold conditions the tool will cycle slower than usual while driving the first nails. The cycle rate will increase as the tool warms up. Keep tool warm to avoid reduced cycle rate.

ADJUSTING THE NAILING DEPTH

⚠ WARNING

Disconnect the tool from the air source before making adjustments. Such precautionary safety measures reduce the risk or unintentional tool operation.

1. Disconnect tool from air supply.
2. Remove nails from the tool.
3. Adjust tool driving depth:
 - To reduce the nail depth, turn the adjustment knob counter clockwise (FIG 8).
 - To drive the nail deeper, turn the adjustment knob clockwise (FIG 9).
4. Reload nails as described in the "Loading Nails" section of this manual.
5. Reconnect air supply.

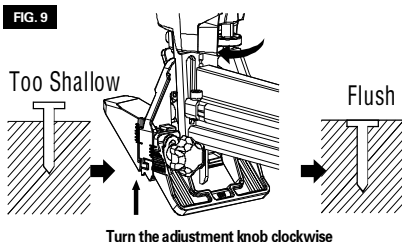
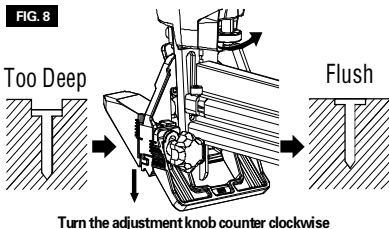

The nailer is equipped with an adjustable depth for flooring, and available for wooden floors of different shapes. This feature allows the user to determine how deep a fastener will be driven into the flooring surface.

1. Loose the screws (FIG. 10, FIG. 11).
2. Adjust the plastic cover to the extend desired (FIG. 12).
3. Tighter the screws (FIG. 13, FIG. 14).

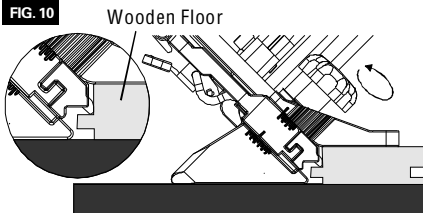
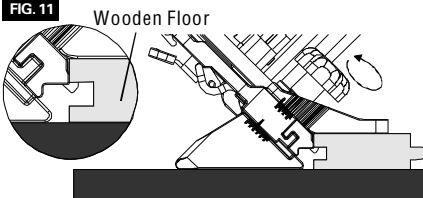
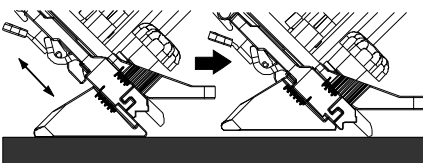
FIG. 10**FIG. 11****FIG. 12**

ADJUSTING THE EXHAUST

The direction of the exhaust vent can be changed by turning the top cover (FIG 13).

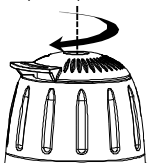
FIG. 13

NAIL INDICATOR

The red indicator bars are used to show when the tool needs to be reloaded (FIG 14). When the tool is loaded with a nail strip, the red indicator bars will no longer be visible in the indicator window. As then nails strip is consumed, the red indicator bars will start to become visible. The tool should be reloaded when the red indicator bar is half way exposed in the indicator window.

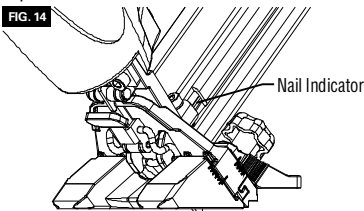
FIG. 14

CHANGE THE NOSE COVER

The tool is packed with another Regular nose cover, with which the nailer can be changed to be regular brad nailer/stapler.

1. Disconnect the tool from air resource.
2. Remove fasteners from the tool. Failure to do so will cause the fasteners to eject from the front of the tool.
3. Pull up on the latch (FIG 15) and open the flooring nose cover (FIG 16).
4. Remove the O-Ring and Pin (FIG 17).
5. Remove the Flooring nose cover (FIG 17).
6. Pull the Regular nose cover (FIG 18) on the nose of the nailer.
7. Put the Pin and O-Ring back (FIG 18/19).
8. Push the latch back to the Nose cover on the nailers nose.

FIG. 15

Quick click lever

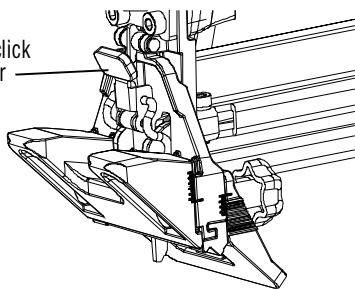
**FIG. 16**

Flooring nose cover

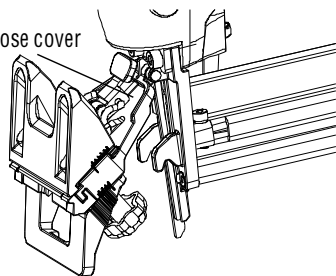
**FIG. 17**

O-Ring Pin

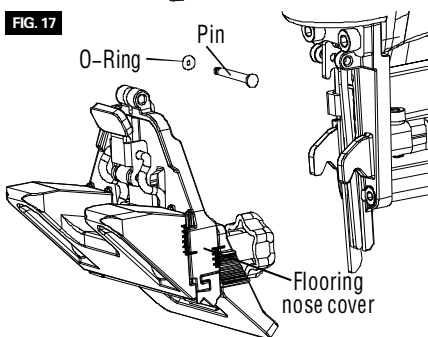
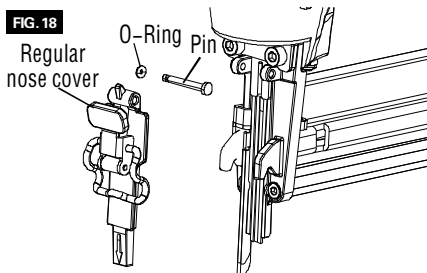
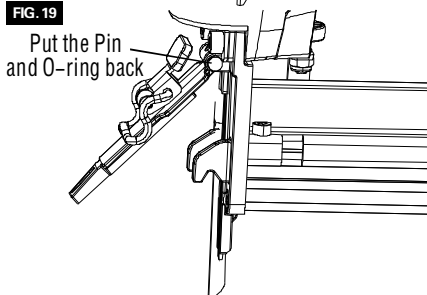
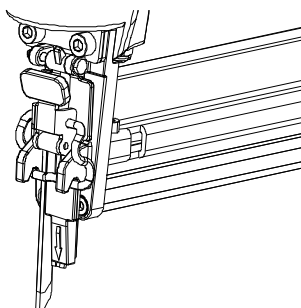

FIG. 18**FIG. 19****FIG. 20**

MAINTENANCE

JAM CLEARING

Remove a jammed nail in the following order:

1. Disconnect air hose.
2. Remove all nails.
3. Failure to do so will cause the fasteners to eject from the front of the tool.
4. Pull up on the latch and open the flooring nose cover.
5. Using caution not to bend or damage the driver blade, using pliers or a screw driver if required to clear the jammed fastener.
6. Close the nose and latch.
7. Reconnect the tool to the air resource.
8. Reload the tool with fastener.

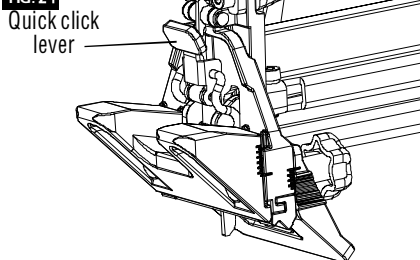
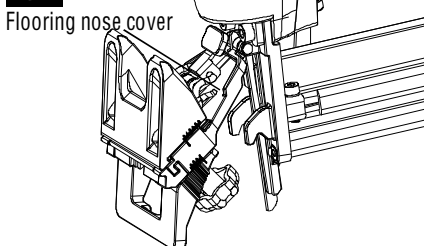
FIG. 21**FIG. 22**

CLEANING

⚠ WARNING

When cleaning a tool be careful not to disassembly any portion of the tool since internal components may be misplaced or safety components may be improperly mounted. Certain cleaning agents such as gasoline, carbon tetrachloride, ammonia, etc. may damage plastic parts and o-rings.

⚠ WARNING

Do not attempt to clean by inserting pointed objects through openings. Sharp edges may damage internal components causing a serious hazard.

Ventilation openings, the work contact element, and the trigger must be kept clean and free of foreign matter. Periodically clean the tool with compressed air.

Clean the magazine. Remove metal or wooden chips which may have accumulated in the magazine. Periodically clean magazine with compressed air.

STORAGE

⚠ WARNING

Keep out of reach of children and personnel unfamiliar with tool operation. Lock the storage area. Tools are dangerous in the hands of personnel unfamiliar with the tool.

When not in use, the tool should be disconnected and stored in the storage case in a warm and dry place. When tool will not be in use for an extended period, apply a thin coat of the lubricant to the steel parts to avoid rust. Do not store the tool in a cold weather environment.

HOOKUP INSTRUCTIONS FOR TOOL TO AIR SUPPLY

NOTE:

For better performance, install a 3/8 inch quick plug (1/4 inch NPT threads) with an inside diameter of 0.315 inch (8mm) on the nailer and a 3/8 inch quick coupler on the air hose.

1. With ON/OFF switch in OFF position, plug compressor into electrical outlet.
2. Close pressure regulator by turning all the way to the left. Turn compressor ON and let it pump all the way up to automatic shut-off pressure.
3. Attach air hose to regulator outlet. Adjust pressure regulator by turning to the right so that outlet pressure is between 70PSI to 110PSI.
4. Load fasteners into nailer.
5. Point the nailer in a safe direction while attaching to air hose.
6. Nailer is ready for use. You may need to adjust outlet pressure to achieve proper fastener depth.

RECOMMENDED HOOKUP

MINIMUM COMPONENTS REQUIRED FOR HOOKUP

Air compressor: The air compressor must be able to maintain a minimum of 70PSI when the nailer is being used. An inadequate air supply can cause a loss of power and inconsistent driving.

Pressure regulator: A pressure regulator is required to control the operating pressure of the nailer between 70PSI and 110PSI.

Air supply hose: Always use air supply hoses with a minimum working pressure rating equal to or greater than the pressure from the power source, or 150PSI, whichever is greater. Use 1/4 inch air hose for runs up to 50 feet. Use 3/8 inch air hose for 50 feet, run or longer.

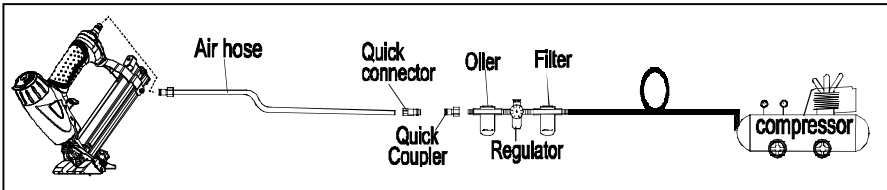

TROUBLE SOLVING

PROBLEMS	POSSIBLE CAUSES	SUGGESTED SOLUTIONS
Air leaking near the top of the tool or in the trigger area.	<ol style="list-style-type: none"> 1. Loose screws. 2. Worn or damaged O-rings or seals. 	<ol style="list-style-type: none"> 1. Tighten screws. 2. Install overhaul kit.
Air leaking near the bottom of the tool.	<ol style="list-style-type: none"> 1. Loose screws. 2. Worn or damaged O-rings or seals. 	<ol style="list-style-type: none"> 1. Tighten screws. 2. Install overhaul kit.
Tool does nothing or operates sluggishly.	<ol style="list-style-type: none"> 1. Inadequate air supply. 2. Tool is too dry. 3. Exhaust blocked. 4. Worn or damaged O-rings or seals. 	<ol style="list-style-type: none"> 1. Make sure the air compressor is set between 70PSI and 110PSI. 2. Add about 2-3 drops of lubrication into the air connector. 3. Clean exhaust channel. 4. Install overhaul kit.
Fasteners are jammed in the tool frequently.	<ol style="list-style-type: none"> 1. Driver channel is worn. 2. Piston is broken or worn. 3. Bent fasteners. 4. Dirty magazine. 5. Loose magazine. 6. Wrong fasteners. 	<ol style="list-style-type: none"> 1. Fix the drive channel. 2. Replace the piston. 3. Remove the bent fasteners, replaced with the right fasteners. 4. Clean magazine. 5. Tighten screws. 6. Verify that fasteners are the correct size.